



AFI-9

ARRAYABLE LOUDSPEAKER SYSTEM

DESCRIPTION:

The AFI-9 is a fully arrayable loudspeaker capable of filling large churches, theaters, sports venues, and theme parks with clean, articulate full bandwidth sound. Available with a 60° x 40° high frequency horn pattern insuring that the AFI-9 works flawlessly in any room configuration.

DRIVER COMPLEMENT:

LOW FREQUENCY: Two Apogee 12" (305mm) neodymium magnet cone-type drivers are constructed of inherently waterproof compounds, providing very high resistance to moisture, enabling long-term stability of cone resonance and cone mass parameters. Magnet structure is encased in an integral heat-sink for long-term high-power applications, lowered distortion, and superb control of short-term impedance rise.

MID FREQUENCY: Two Apogee 6-1/2" (165mm) permanent magnet cone-type drivers are treated with waterproofing compound. In addition, a unique baffle mounting arrangement protects the driver cones from direct ingress of water or foreign elements. A totally enclosed frame design isolates the back wave output from interference with the low frequency chamber and protects the cone from any ingress of particles or moisture.

HIGH FREQUENCY: One Apogee 4" (100mm) voice coil, 2" (51mm) exit horn-loaded compression driver, driven by a powerful neodymium magnet structure; diaphragm is constructed of ceramic-coated metal alloy. The use of the most up-to-date Ferrotec Ferrofluid® developed for compression drivers assures greater power handling capability and lower distortion, and ensures that the short- and long-term impedance rises are minimal.

INPUT CONNECTORS:

Barrier strip, screw type #8

COMPATIBLE PROCESSORS:

Apogee DLC24 Digital Processor

HANDLES:

Two handles – one top, one bottom – designed as an integral part of the enclosure (no moving parts)

GRILLE:

Highly durable, heavy gauge steel with a quality powder-coated finish (aluminum used on SX version)

RIGGING HARDWARE:

Six rigging points, three each on top and bottom, backed with 16-gauge steel plates; plates can be type 3/8"-16 or M10 thread

FINISH:

Textured high-strength black epoxy paint; other colors optional

ENCLOSURE TYPE:

30 degree trapezoidal design with point-source radiation pattern

CABINET CONSTRUCTION:

Multi-ply, void-free hardwood

OPTIONS/ACCESSORIES:

- Apogee DLC24 Digital Processor
- "SX" weather treatment for harsh environments
- Assorted rigging components

ENGINEERING DATA:

FORMAT:

AFI-9 Passive/Three-way

DISPERSION:

H: 60° x **V:** 40°

FREQUENCY RESPONSE

(1M ON AXIS, W/DLC24 PROCESSOR):
55 Hz to 20 kHz ± 3 dB

MAX. SPL (@1M):

AFI-9 130 dB cont./136 dB peak

PTML (PEAK TRANSIENT MECHANICAL LIMIT):

AFI-9 147 dB

SENSITIVITY (1W @ 1M):

AFI-9 104 dB SPL/100 Hz to 10 kHz

NOMINAL IMPEDANCE:

SYSTEM: 16 ohms

LF: 2 x 8 ohms = 16 ohms

MF: 2 x 8 ohms = 16 ohms

HF: 1 x 8 ohms = 8 ohms

MAX. POWER HANDLING:

AFI-9 600W cont./2400W peak

DIMENSIONS:

front: 28.25" (717mm) W x 30.83" (783mm) H

rear: 15.39" (391mm) W x 30.83" (783mm) H

depth: 24.95" (634mm)

WEIGHT:

144 lb. (65.3 kg)



POLAR MEASUREMENTS AFI-9 (6 dB/division, normalized)

FREQUENCY RESPONSE AFI-9

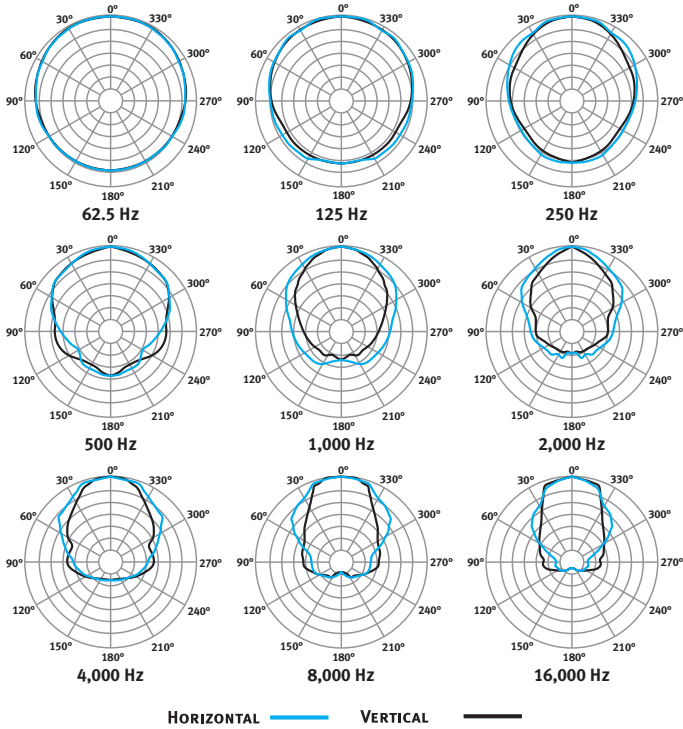

All polar measurements obtained in a free-field environment at 10° increments.

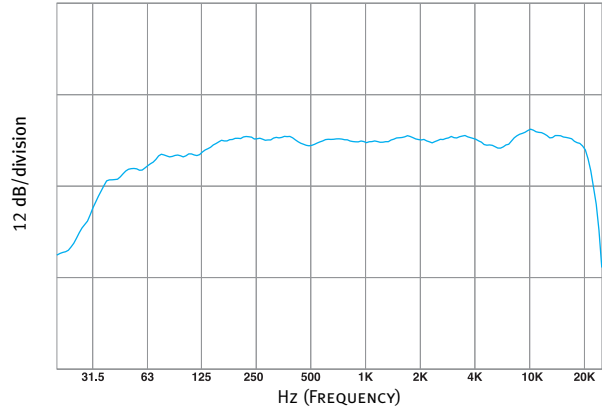

Measured in a free-field anechoic environment using a swept one-third octave input.

PROCESSOR NOTES:

The DLC24 Digital Loudspeaker Controller is a digital engine with an analog surface. It combines the most advanced technology available with intuitive interfaces to provide the key elements that ensure optimal loudspeaker system performance and management in a variety of live sound and fixed installation applications. The controllers provide factory-set equalization curves to smooth the response, protective limiting, and active crossovers (for bi-amplified models and subwoofers). XLR inputs and outputs are standard on the DLC24.

DIMENSIONAL DRAWINGS AFI-9 (dimensions in inches and millimeters)

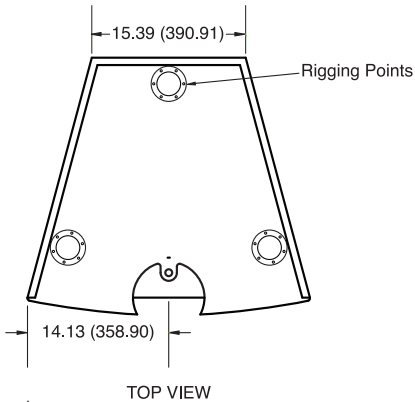
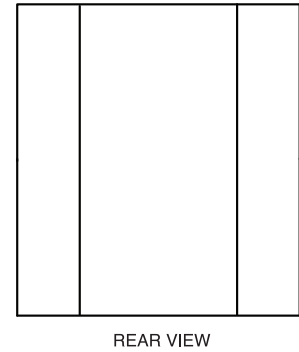
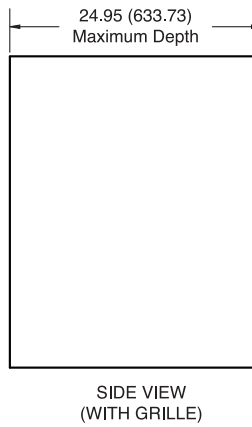
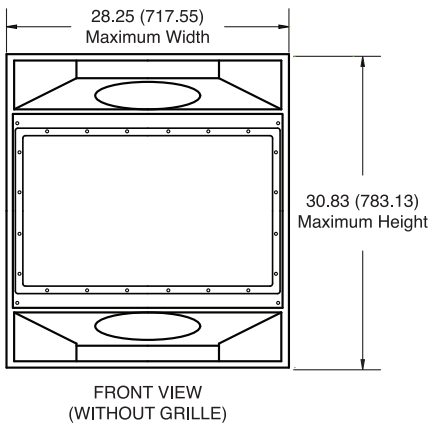

50 SPRING STREET, RAMSEY, NJ 07446, USA
 TEL: 800-443-3979 • FAX: 800-999-9016 • www.apogee-sound.com